

Design of USB-based High Rate Data Communication for Transcranial Doppler Ultrasound System

Bat-Erdene Byambasuren¹, Mandakh Oyun-Erdene², Sang-Yep Nam³,
Dong-Han Kim^{1*} and Seung-Moo Han³

¹*Department of Electrical Engineering, Kyung Hee University, Korea*

²*Department of Electrical Engineering, Kukje University, Korea*

³*Department of Biomedical Engineering, Kyung Hee University*

*Corresponding Author: donghani@khu.ac.kr

{baterdene, mandakh, smhan}@khu.ac.kr, synam58@gmail.com

Abstract

A Transcranial Doppler ultrasound system measures blood flow velocity of brain vessels. It displays power spectrum density to the computer display and measures other important parameters. For this measurement, transmission speed between equipment and a computer plays an important role. In order to provide processing of high rate data communication, most Transcranial Doppler ultrasound systems use digital signal processor which performs the process in hardware and is connected by a universal serial bus controller to the processor. This research presents a new design of the Transcranial Doppler ultrasound system using CY7C68013 without digital signal processor and general programmable interface waveform of the CY7C68013 for the Transcranial Doppler ultrasound system. Also, this research describes control library for the personal computer and implemented software. According to the implemented software, the processing of Transcranial Doppler ultrasound system can be carried out.

Keywords: *Transcranial Doppler Ultrasound, GPIF, Data Transformation Formatting, USB Communication, CY7C68013*

1. Introduction

A Transcranial Doppler (TCD) ultrasound system measures blood flow velocity of brain vessels, and performs signal processing, that generates Power Spectrum Density (PSD) of blood flow velocity and some important parameters to the computer display. It measures the velocity of blood flow in the intracranial major arteries, which includes basilar artery (BA), left and right anterior cerebral arteries (LACA, RACA), left and right internal carotid arteries (LICA, RICA), left and right middle cerebral arteries (LMCA, RMCA), left and right posterior cerebral arteries (LPCA, RPCA), and left and right vertebral arteries (LVA, RVA). Also, it utilizes 2MHz and 4MHz ultrasound probes, and is based on the detection of frequency shifting from red blood cells which are moving via brain vessels. Then the TCD ultrasound system diagnoses different types of diseases such as emboli, stenosis, and vasospasm from a subarachnoid hemorrhage [1]-[3]. Also, the measured signal is processed by the system and is separated depending on direction of blood flow. The separated signal is converted to a sound signal, and is generated for sound card of the Personal Computer (PC) [4-6].

The main structure of TCD ultrasound equipment is composed of hardware and software systems. For signal processing, the transmission process of real and imaginary signals is

necessary. It is transmission process from the hardware to the software section via a communication interface in the real time. In software section, the system carries out Complex Fast Fourier Transform (FFT) and noise reduction processing using real and imaginary received signal from communication interface. After processing, PSD of blood flow velocity and some important parameters are displayed. Sometimes, it is displayed by M-mode depending on depth of brain vessel [7-12]. In this case, signal processing for every depth is carried out using Digital Signal Processor (DSP) in hardware. Then the processed signal is transmitted to software, which is used for image of the PSD and other important computations. However, there is no system without DSP in the hardware section that directly receives the real and imaginary signals and executes processing of the M-mode in software section.

In this research, the Universal Serial Bus (USB) driver design and realization is presented. The proposed approach is based on the TCD ultrasound system without DSP in hardware section, which directly transmits the real and imaginary signals to software section at real time. The USB driver design is simple and an economical viable solution as implemented hardware that does not use DSP.

2. Structure of System Hardware

The main structure of TCD ultrasound system is shown in Figure 1. In order to measure blood flow velocity, the system transmits ultrasound signals with high frequency, and calculates shift frequency using reflected signal from brain vessels. First, the received signal is demodulated and then generates quadrature signal with 90° phase.

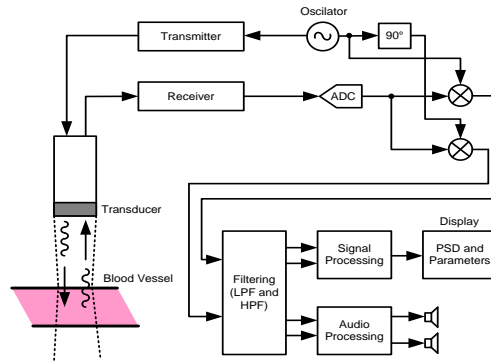

Figure 1. Main Structure of TCD Ultrasound System

The quadrature signal is filtered by the system and after processing, the system executes signal and audio processing. The signal processing section includes calculation of some important parameters such as peak velocity, mean velocity, diastole velocity, systole/diastole, pulsatility index, resistance index and heart rate. Also, it includes image of the PSD depending on the depth of brain vessel [13]. However, the audio processing section includes separation depending on direction of blood flow, noise reduction processing of audio signals, interpolation processing and generation of audio signals to sound card of computer [13-14]. In order to carry out the signal and audio processing on the PC, filtered signals must be transmitted to the PC via a communication interface. A new communication interface is shown in Figure 2, which can carry out above processes.

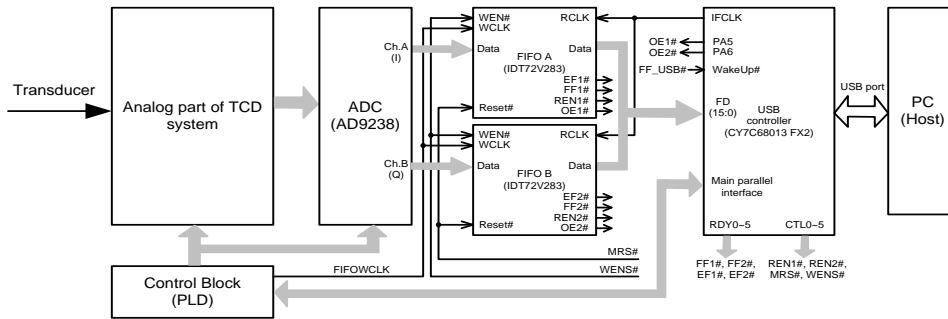

Figure 2. The Block Diagram of HRDC Interface using USB for TCD Ultrasound System

The CY7C68013 FX2 is used in High Rate Data Communication (HRDC) interface and First-In-First-Out (FIFO) IDT72V283 is used in each section of the real and imaginary signal processing for high speed transmission. The CY7C68013 FX2 is a single chip that can transmit data to the PC through USB port [15]. The IDT72V283 is high speed FIFO memory with clock reading and writing control and flexible Bus-Matching x9/x18 data flow [16].

USB controller is connected to FIFO by General Programmable Interface (GPIF) interface. In order to transmit control signal, USB controller is connected to Control block by main parallel interface. The Control Block performs following activities: analog signal conversion, data transmission of FIFO and control signal transmission to USB controller. Figure 3 illustrates the hardware of the implemented USB interface.

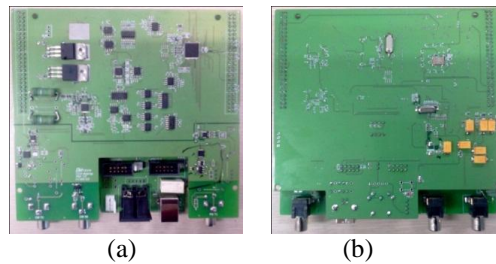

Figure 3. The Picture of Hardware for TCD Ultrasound System: (a) Front Side of System, (b) Back Side of System

3. The design of USB

3.1. USB Interface Algorithm

Figure 4 depicts the flow of the USB interface algorithm. The algorithm consists of two parts. The first part is transmission section that transmits the real and imaginary signals to PC with GPIF interface. First, this part starts re-numeration process of USB and gives start values of GPIF. Furthermore, this part calls GPIF waveform when FIFO is connected to the USB controller.

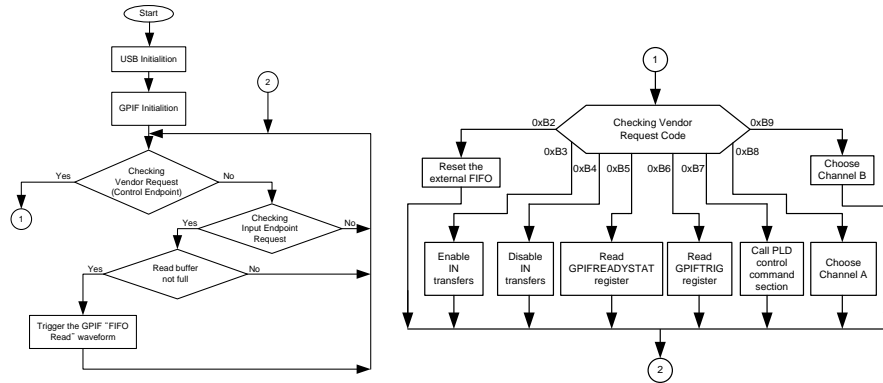

Figure 4. The Main Algorithm of the USB Interface

Then, control endpoint request is checked. If the control endpoint request is not received, input endpoint request will be checked. If the input endpoint request is received, the algorithm will check that read buffer is not full. Then, it will receive the real and imaginary signals from external FIFO through GPIF waveform and restart checking process. But, if the control endpoint request is received, program pointer will be moved into second part.

The second part is realization of the control commands, that is connected with the Control Block. The control commands consist of the functions like: Reset external FIFO, Enable IN transfers, Disable IN transfers, Read GRIFREADYSTAT register, Read GRIFTRIG register, Call Programmable Logic Device (PLD) control command section, Choose ‘Channel-A’, Choose ‘Channel-B’. Above commands can perform follows: to reset FIFO, to enable and disable information transmission of read buffer, to read some status register, and to communicate with PLD part.

3.2. GPIF Block Diagram and Waveform

The USB controller can be connected with FIFO through GPIF interface. In this case, GPIF block diagram and waveform, as shown in Figure 5 are used. ‘GPIF Designer’ software is employed for waveform design. First, this waveform performs reset process, and then starts Analog Digital Converter (ADC) conversion. It waits still end of the ADC conversion. When the ADC conversion is finished, waveform starts process of reading data from external FIFO. Firstly, the real signal is collected from FIFO ‘Channel-A’. Finally, waveform collects the imaginary signal from FIFO ‘Channel-B’.

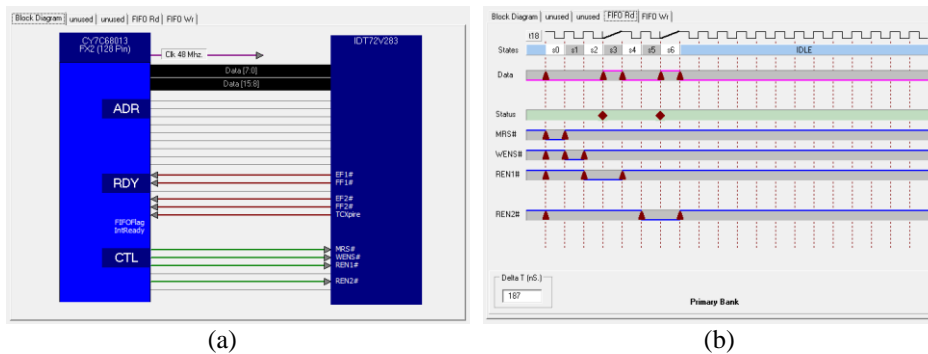

Figure 5. GPIF Design: (a) Block Diagram, (b) Waveform

The programmable states of the USB interface are shown in Figure 6. Those include seven states that include two decision points, five non-decision points and one idle state. All data of the FIFO ‘Channel-A’ and the FIFO ‘Channel-B’ are transmitted into the PC at the first and second decision point, respectively. In this time, two decision states check flags of Empty Flag 1 (EF#1) and Empty Flag 2 (EF#2). If all data of the FIFO ‘Channel-A’ and the FIFO ‘Channel-B’ are transmitted, program pointer will be moved to idle state.

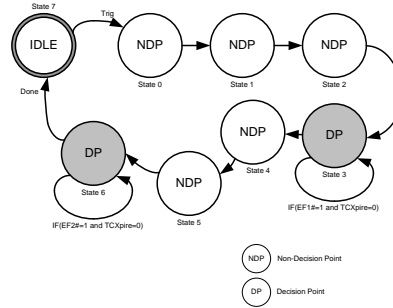

Figure 6. The Programmable States of the USB Interface

3.3. Data Bus Format and Waveform

In this new communication interface, the USB controller is connected to FIFO by 16 bit data bus, and communication data content of the real and imaginary signals consist of 12 bit. But, content of remaining 4 bit transmits additional depth information of brain vessel about communication data content of 12 bit. Figure 7 shows the transmission data format of FIFO.

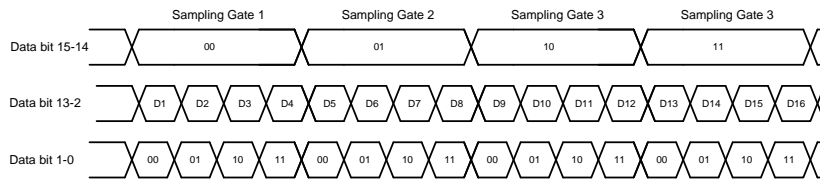

Figure 7. Transmission Data Format of FIFO

Data stream of this format is divided four sampling gates. Selection of all sampling gates is separated by content of data bit from 14 to 15. Four depth data can be transmitted for each sampling gate. Then, each depth data of brain vessel is separated by data bit from 0 to 1. In this transmission data format, 16 depth data are transmitted, which is called D1-D16. Each depth data content is transmitted by data bit 2-13. In this case, image of M-mode can be generated according to this 4 bit, which includes all depth information of measured brain vessel.

4. The Implemented Software

In this research, a new library is described, which can be communicated computer software of the USB interface. It is called ‘usb_driver_tcd.dll’. The library performs control of data transmission of the real and imaginary signals receiving from external FIFO and control commands. On the other hand, this library can directly access with the USB interface. The structure of the library for the USB interface is shown in Figure 8.

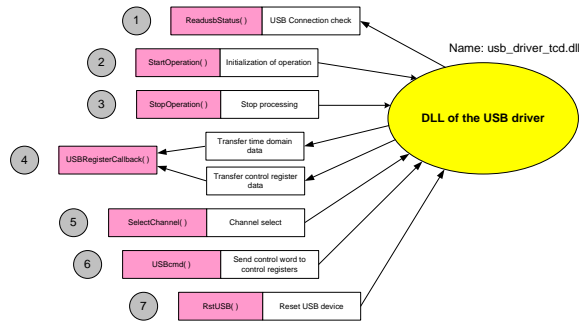

Figure 8. The Structure of the Library for the USB Interface

The library for the USB interface includes following 7 functions: ReadusbStatus(), StartOperation(), StopOperation(), USBRegisterCallback(), SelectChannel(), USBcmd() and RstUSB(). These functions are used for processing of the TCD ultrasound system. ReadusbStatus() function can check connection of the USB interface with the PC. StartOperation() and StopOperation() functions can send out connection request of the USB interface. Also, those functions can start and stop process. SelectChannel() can select FIFO ‘Channel-A’ and ‘Channel-B’. USBRegisterCallback() function can read external FIFO data and separate 12 bit content of the ADC data including the real and imaginary signals from all data. Also, it can generate depth information of brain vessel from remaining 4 bit content of ADC data. RstUSB() function can reset process. But, USBcmd() function can communicate control words with external PLD. Control block is designed by the PLD, which is programmed several control registers that relates with the TCD ultrasound system. This function can directly access to those control registers.

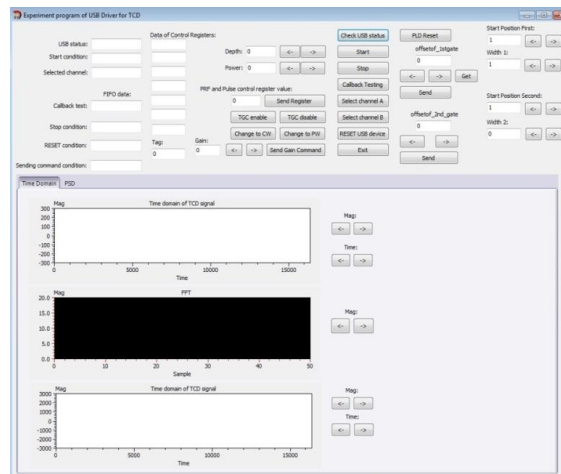

Figure 9. The Implemented Software for the USB Interface

Figure 9 shows the implemented software for the USB interface. The implemented software for the USB interface shows time and frequency domain of real and imaginary signals and image of PSD. Also, it can communicate the control signals of the USB interface. The control signals are comprised by follows: depth of probe transmitted signal of TCD ultrasound system, regulation power of probe transmitted signal, mode selection of Pulsed Wave (PW) and Continued Wave (CW), gain control commands, and PLD reset command.

5. Experiment Results

In this research, some experiment is carried out by this implemented USB interface utilizing 2MHz probe. The experiment data is obtained by our implemented software from brain vessels of BA, LVA and LMCA. Figure 10, 11 and 12 show the experiment results, which include time domain of the real and imaginary signals, spectrum and the PSD of obtained signal.

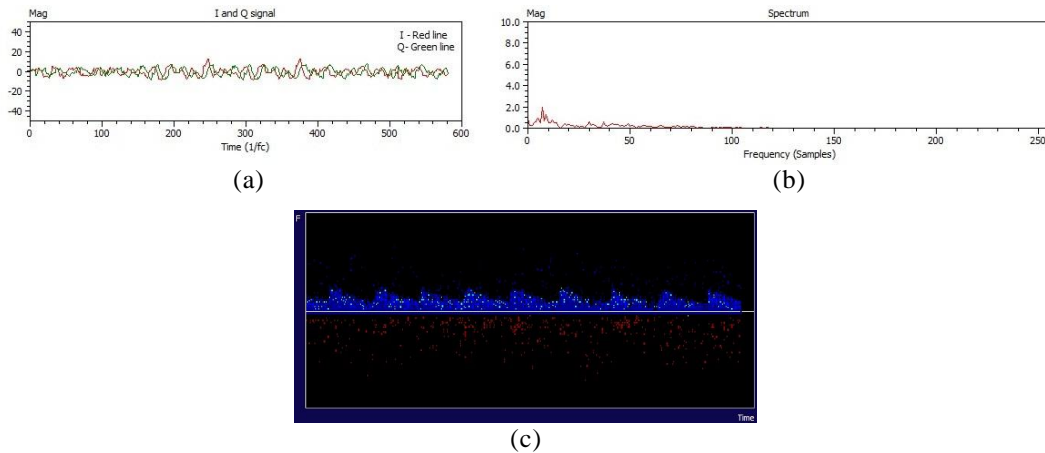

Figure 10. Experiment Results of BA: (a) Time Domain of Real and Imaginary Signals, (b) Spectrum of Obtained Signals, (c) PSD of BA

From the experiment results, we can see that some important parameters of brain vessel are good response on the each brain vessel. Also, forward and reverse directions of blood flow are good separated from PSD graphics. In this case, BA and LVA are opposite direction with LMCA.

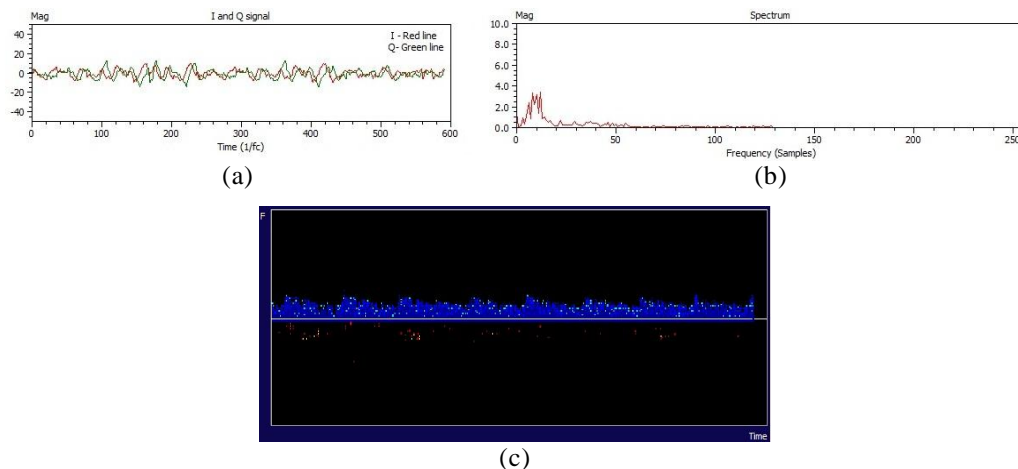

Figure 11. Experiment Results of LVA: (a) Time Domain of Real and Imaginary Signals, (b) Spectrum of obtained Signals, (c) PSD of LVA

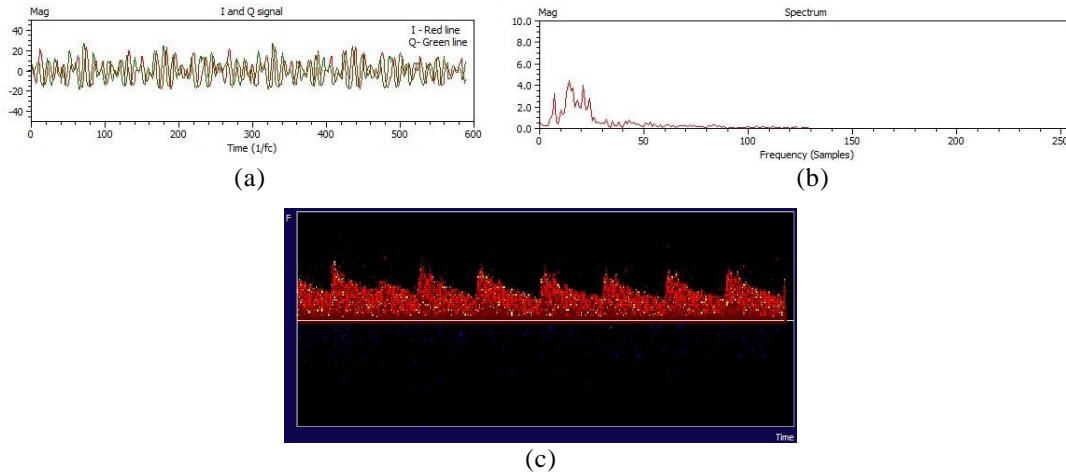

Figure 12. Experiment Results of LMCA: (a) Time Domain of Real and Imaginary Signals, (b) Spectrum of obtained Signals, (c) PSD of LMCA

6. Conclusions

The proposed interface becomes simple and cost effective solution. In this research, the implemented hardware of the USB interface, working flowchart of the USB interface, GPIF block diagram and waveform, the programmable states of the USB interface, implemented software library and implemented software are described. The results of implemented system suggest the possibility of using signal processing of the TCD ultrasound system without DSP in hardware.

Also, image of the M-mode is possible using this economical solution because computer software can receive depth information of brain vessel using additional 4 bit of the data bus at the real time.

Acknowledgements

This research was supported by a grant from the Construction Technology Innovation Program (CTIP) (No. 10CCTI-A050948-04) funded by the Ministry of Land, Transportation and Maritime Affairs (MLTM) of the Korean government, and the Industrial Strategic Technology Development Program (No. 10035544-2010-01) funded by the Ministry of Knowledge Economy (MKE), Korea. The first author is grateful to Prof. Seung-Moo Han for your contributions to this research.

References

- [1] K. F. Tang, L. M. Brass, T. K. Tatemichi, D. Duterte, R. L. Sacco and J.P. Mohr, "Transcranial Doppler in Cerebrovascular Disease", *J. Sing.Med*, (1988), pp. 489-497.
- [2] S. M. Hugh, "Transcranial Doppler Ultrasound", *J. British Medical Bulletin*, vol. 56, no. 2, (2000), pp. 378-388.
- [3] I. K. Moppett and R. P. Mahajan, "Transcranial Doppler Ultrasonography in Anaesthesia and intensive care", *J. British Journal of Anaesthesia*, vol. 93, no. 5, (2004), pp. 710-724.
- [4] G. Bambi, P. Fidanziati, T. Morganti, S. Ricci and P. Tortoli, "Real-Time Digital Processing of Doppler Ultrasound Signals.", *ICASSP*, (2005), Italy.
- [5] B. Tatsuro, "Direction Separation in Doppler Audio of Ultrasound Diagnosis Equipment: Signal Processing for Doppler Audio Dealiasing", *J. Acoust. Sci. & Tech.*, vol. 28, no. 3, (2006), pp. 202-210.

- [6] Y. L. Mo. Larry and M. K. Richard, "Method and Apparatus for Dynamic Noise Reduction for Doppler Audio Output", UK, (2001).
- [7] M. A. Moehring and M. P. Spencer, "Power M-mode Doppler for observing cerebral blood flow and tracking emboli", *J. Ultrasound in Med. & Biol.*, vol. 28, no. 1, (2001), pp.49-57.
- [8] M. A. Moehring, "Doppler Ultrasound Method and Apparatus for Monitoring Blood Flow", United States Patent. USA, (2001).
- [9] G. John, C. Joanne and H. E. David, "Implementation of a Field Programmable Gate Array Based Transcranial Doppler Ultrasound System Using Pulse Compression Techniques", UK, (2007).
- [10] N. Aydin and D. H. Evans, "Implementation of Directional Doppler Techniques Using a Digital Signal Processor", *J. Med. Bio. Eng. Comput.*, (1994), pp. 157-164.
- [11] A. Nizamettin and H. E. David, "A Fast Frequency Domain Algorithm for Decoding Quadrature Doppler Signals", 18th Annual Int. Conf. of the IEEE Eng. in Medicine and Biology Society, (1996), pp. 993-994, Amsterdam.
- [12] B. Liu, Y. Wang and W. Wang, "Spectrogram Enhancement Algorithm: a Soft Thresholding-Based Approach", *J. Ultrasound Med. Biol.*, (1999), pp. 839-846.
- [13] A. Naranchimeg, B. Bat-Erdene, K. Dong-Han and H. Seung-Moo, "Real Time Method for Noise Reduction of Directional Doppler Audio Signals", *Proceedings of Int. Conf. on knowledge based Industry*, (2011), pp. 47-50, Ulaanbaatar, Mongolia.
- [14] P. Fidanzati, T. Morganti and P. Tortoli, "Real-Time Software Processing and Audio Reproduction of Directional Doppler Signals", *J. Ultrasound in Medicine & Biology.*, vol. 31, (2005), pp.1735-1741.
- [15] Company of CYPRESS, EZ-USB FX2 Technical Reference Manual, USA.
- [16] Company of IDT, Data sheet of Volt High-Density Super sync II Narrow Bus FIFO, (2003).

