

Control Strategies for DFIG Based Grid Connected Wind Energy Conversion System

Aggarwal Archana¹, Saini Lalit Mohan² and Singh Bhim³

¹Deptt. Of Electronics Engg., YMCA University of Sc. & Technology, Faridabad, Haryana, India

²Deptt. Of Electrical Engg., NIT Kurukshetra, Haryana, India

³Deptt. of Electrical Engg., IIT, Delhi, India

Abstract

This paper deals with the modelling and control of a doubly-fed Induction generator (DFIG) based grid connected wind energy conversion system. Back to back Pulse width modulated insulated gate bipolar transistors (IGBT) based voltage source converters (VSC) have been used for the control. The complete mathematical analysis of stator flux oriented control and stator voltage oriented control of DFIG based wind system has been done. Maximum power tracking has been done through rotor speed control. The proposed electromechanical system is modelled and simulated in MATLAB using Simulink and Sim power system toolboxes. The performance of the system for both the control strategies is presented to demonstrate the difference between the two.

Keywords: DFIG, grid voltage oriented control, renewable energy, stator flux oriented control, wind energy conversion

1. Introduction

Renewable energy resources have attracted attention worldwide due to scarcity and rising prices of fossil fuels. These are considered to be important in improving the reliability of energy supplies by minimising the dependency of fossil fuels and reducing the emission of greenhouse gases. Wind turbines can be either constant speed, which rotate at a constant speed irrespective of wind speed or variable speed in which speed varies in accordance with the wind speed. In the early stage of wind power development, the fixed speed wind turbines with squirrel cage induction generators were in use. Energy efficiency is very low for fixed speed wind turbines for varying wind speed.

In recent years, wind turbine technology has shifted from fixed speed to variable speed. Variable speed machines have various advantages. They reduce mechanical stresses, dynamically adjust in case of power or torque pulsations and improve power quality and efficiency. Various generators can be used for the variable speed operation of wind turbine. But, variable speed operation of wind turbine using DFIG is very attractive because of its many inherent advantages. Generator speed can be varied below and above the synchronous speed within a specified range which further depends on the rating of converters. Converters handle only slip power which is just a fraction of the total power. This leads to the reduction in the converter rating and hence the reduced cost [1, 2]. The bidirectional power flow is achieved by using back to back pulse width modulated Insulated gate bipolar transistors based voltage source converters with a common d.c. link. In grid connected systems, these converters are referred as rotor side converter and grid side converter. In case of standalone systems, where grid is not there, grid side converter is named as load side converter. In this configuration, decoupled active and reactive power control is obtained using stator voltage oriented control or stator flux oriented control of rotor side converter.

Lots of research work has been reported on wind turbines based on DFIG. In [3-7], stator flux oriented control has been used for rotor side converter. Sensorless control as well as stator flux oriented control has been reported in [7]. Dynamic modelling of DFIG along with stator flux oriented control has been discussed in [8, 9]. Independent active and reactive power control along with power factor control of stator side, improvement in power quality is obtained using stator voltage oriented control [10]. Voltage control at PCC with independent active and reactive power control using stator voltage oriented control is reported in [11]. [12, 13] use stator flux oriented control for standalone wind energy conversion systems along with harmonic elimination and sensorless control. Fault Ride through capability of DFIG based grid connected wind system is reported in [14]. In this paper, the complete mathematical analysis of both the techniques has been done. Control of both the converters has been developed. The performance of rotor converter using stator flux oriented control as well as stator voltage oriented control has been shown.

2. Modelling of DFIG

The equivalent circuit of DFIG in dq reference frame is:

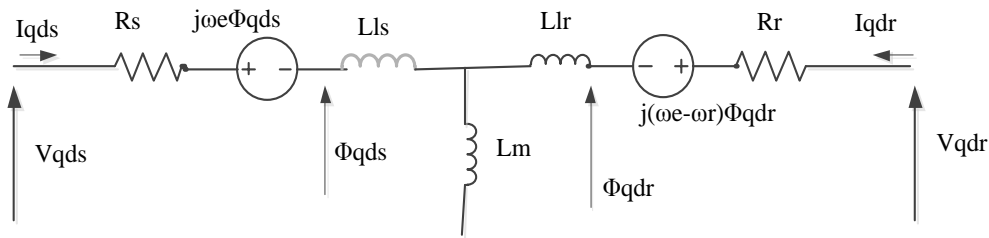

Figure 1. Equivalent Circuit of DFIG

The various equations representing the behaviour of DFIG in dq reference frame are:

$$V_{qs} = R_s I_{qs} + \frac{d\phi_{qs}}{dt} + \omega_e \phi_{ds} \quad (1)$$

$$V_{ds} = R_s I_{ds} + \frac{d\phi_{ds}}{dt} - \omega_e \phi_{qs} \quad (2)$$

$$V_{dr} = R_r I_{dr} + \frac{d\phi_{dr}}{dt} - (\omega_e - \omega_r) \phi_{qr} \quad (3)$$

$$V_{qr} = R_r I_{qr} + \frac{d\phi_{qr}}{dt} + (\omega_e - \omega_r) \phi_{dr} \quad (4)$$

$$\phi_{ds} = L_s I_{ds} + L_m (I_{ds} + I_{dr}) \quad (5)$$

$$\phi_{qs} = L_s I_{qs} + L_m (I_{qs} + I_{qr}) \quad (6)$$

$$\phi_{qr} = L_r I_{qr} + L_m (I_{qs} + I_{qr}) \quad (7)$$

$$\phi_{dr} = L_r I_{dr} + L_m (I_{ds} + I_{dr}) \quad (8)$$

$$P_s = \frac{3}{2} (V_{ds} I_{ds} - V_{qs} I_{qs}) \quad (9)$$

$$Q_s = \frac{3}{2} (V_{qs} I_{ds} - V_{ds} I_{qs}) \quad (10)$$

3. Stator Voltage Oriented Control

In this scheme, stator voltage vector is oriented along the d-axis. Hence $V_{qs} = 0$.
From the power equations (9) and (10)

$$P_s = \frac{3}{2} V_{ds} I_{ds} \quad (11)$$

$$Q_s = -\frac{3}{2} V_{ds} I_{qs} \quad (12)$$

the active power $\propto I_{ds}$ and reactive power is proportional to I_{qs}

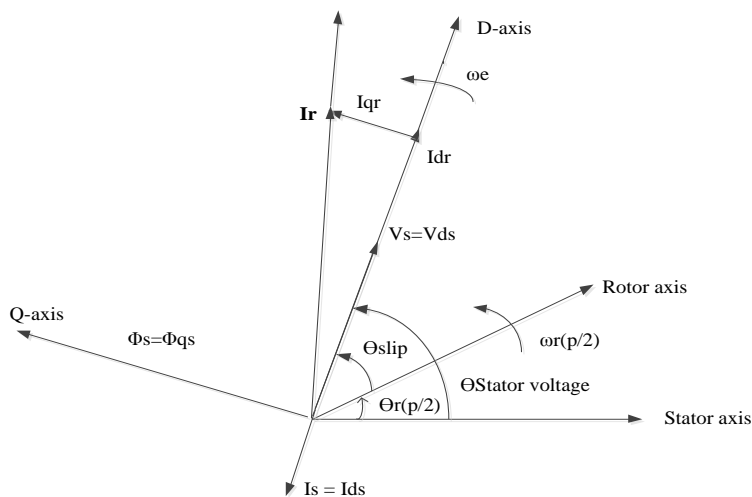

Figure 2. Vector Diagram for Stator Voltage Oriented Control

3.1. Grid Side Converter Control

The main function of grid side converter is to maintain d.c. link voltage constant as well as to facilitate the bi-directional power flow between rotor side converter and grid in sub as well as super synchronous mode

At d.c. link:

$$\frac{1}{2} C V_{dc}^2 = P_g - P_r \quad (13)$$

$$C V_{dc} \frac{dV_{dc}}{dt} = P_g - P_r \quad (14)$$

$$C \frac{dV_{dc}}{dt} = \frac{P_g}{V_{dc}} - \frac{P_r}{V_{dc}} = i_{og} - i_{or} \quad (15)$$

$$v_{d1} = -(RI_d + L \frac{dI_d}{dt}) + \omega_e LI_q + v_d \quad (16)$$

$$v_{q1} = -(RI_q + L \frac{dI_q}{dt}) - \omega_e LI_d \quad (17)$$

The control equations of the grid side converter are:

$$v_{q1}^* = -(k_{p2} + k_{i2} \int)(I_q^* - I_q) + \omega_e LI_d + v_q \quad (18)$$

$$v_{d1} = -(k_{p1} + k_{i1} \int)(I_d^* - I_d) + \omega_e LI_q + v_d \quad (19)$$

I_d^* is obtained from the error in desired and actual d.c. link voltage while I_q^* is obtained from the required reactive power component of current.

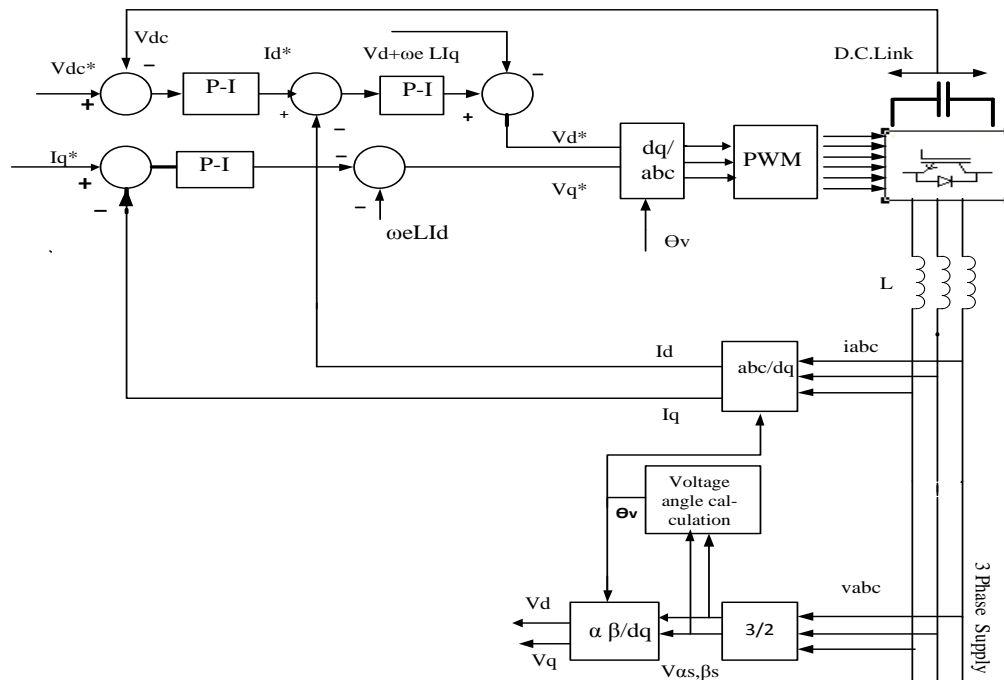

Figure 3. Vector Control for Grid Side Converter

3.2. Rotor Side Converter Control

Control on the rotor end converter is used to program the active and reactive power generated by the DFIG. As the d-axis is aligned along the stator voltage vector, as per equation (11) &(12)

$$P_s \propto I_d \text{ and } Q_s \propto I_q$$

Reproducing equation (3) from DFIG modelling

$$V_{dr} = R_r I_{dr} + \frac{d\phi_{dr}}{dt} - (\omega_e - \omega_r)\phi_{qr}$$

Substituting the value of ϕ_{dr} and ϕ_{qr} from equation (7) & (8)

$$V_{dr} = R_r I_{dr} + \frac{d(L_r I_{dr} + L_m(I_{ds} + I_{dr}))}{dt} - (\omega_e - \omega_r)[L_r I_{qr} + L_m(I_{qs} + I_{qr})] \quad (20)$$

Substituting $L_r = L_{lr} + L_m$ and $L_s = L_{ls} + L_m$, we get

$$V_{dr} = R_r I_{dr} + L_r \frac{dI_{dr}}{dt} + L_m \frac{dI_{ds}}{dt} - (\omega_e - \omega_r)(L_r I_{qr} + L_m I_{qs}) \quad (21)$$

In stator voltage oriented control, $V_{qs} = 0$, as the flux is at 90° w.r.t. voltage.

$$\text{So, } \phi_{ds} = 0 = L_s I_{ds} + L_m I_{dr} \quad (22)$$

$$I_{ds} = -\frac{L_m}{L_s} I_{dr} \quad (23)$$

$$\frac{dI_{ds}}{dt} = -\frac{L_m}{L_s} \frac{dI_{dr}}{dt} \quad (24)$$

Substituting the value of $\frac{dI_{ds}}{dt}$ and $\sigma = 1 - \frac{L_m^2}{L_s L_r}$ in equation (21)

$$V_{dr} = R_r I_{dr} + \sigma L_r \frac{dI_{dr}}{dt} - (\omega_e - \omega_r)(L_r I_{qr} + L_m I_{qs}) \quad (25)$$

Similarly from the equation of V_{qr} in DFIG modelling

$$V_{qr} = R_r I_{qr} + L_r \frac{dI_{qr}}{dt} + L_m \frac{dI_{qs}}{dt} + (\omega_e - \omega_r)(L_r I_{dr} + L_m I_{ds}) \quad (27)$$

From equation (6)

$$I_{qs} = \frac{1}{L_s} [\phi_{qs} - L_m I_{qr}] \quad (28)$$

$$\Rightarrow L_m \frac{dI_{qs}}{dt} = \frac{L_m}{L_s} \frac{d\phi_{qs}}{dt} - \frac{L_m^2}{L_s} \frac{dI_{qr}}{dt} \quad (29)$$

From equation (27)

$$V_{qr} = R_r I_{qr} + L_r \sigma \frac{dI_{qr}}{dt} + (\omega_e - \omega_r)(L_r I_{dr} + L_m I_{ds}) \quad (30)$$

Equation (25) and (30) can be written in control equations as

$$V_{dr} = (k_{p3} + k_{i3} \int)(I_{dr}^* - I_{dr}) - (\omega_e - \omega_r)L_r I_{qr} - (\omega_e - \omega_r)L_m I_{qs} \quad (31)$$

$$V_{qr} = (k_{p4} + k_{i4} \int)(I_{qr}^* - I_{qr}) + (\omega_e - \omega_r)L_r I_{dr} + (\omega_e - \omega_r)L_m I_{ds} \quad (32)$$

Value of I_{dr}^* and I_{qr}^* are calculated from the error in speed and the required reactive power to be transmitted from the rotor. Desired value of speed is obtained from the MPPT curve of wind turbine.

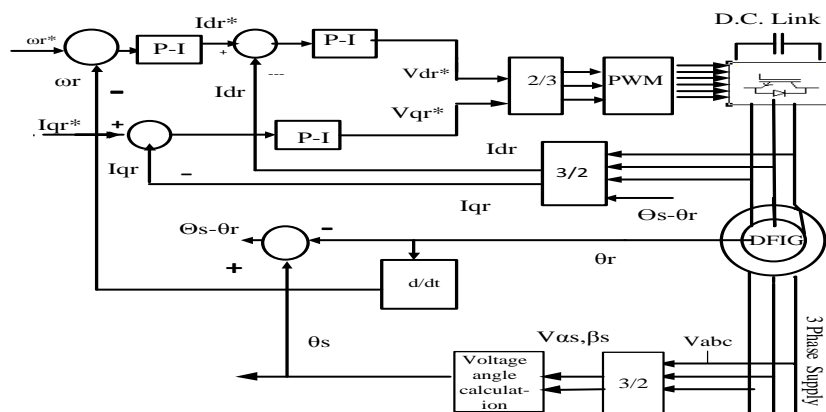

Figure 5. Vector Control for Rotor Side Converter

4. Stator Flux Oriented Control

In stator flux oriented control, stator flux is oriented along d-axis, so voltage gets along the q-axis. i.e. $V_{ds} = 0$; So, $P_s \propto I_q$ and $Q_s \propto I_d$. Hence active power is controlled by q-component of current and reactive power is controlled by d-component of current. It is just the reverse of stator voltage oriented control.

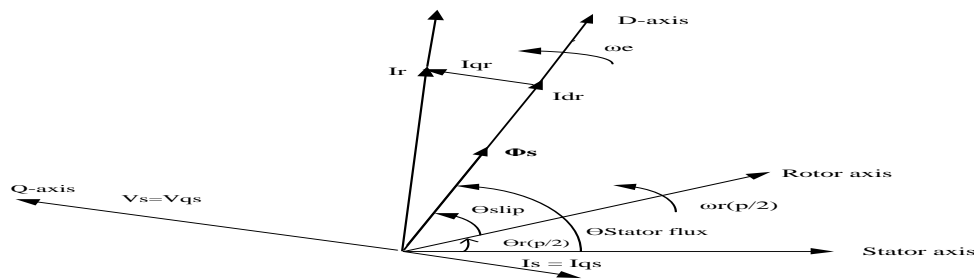

Figure 4. Phasor Diagram for Stator Flux Orientation

4.1. Rotor End Converter Control

Since the control of induction generator is through rotor currents, stator quantities are represented in terms of rotor quantities.

Substituting $\phi_{qs} = 0$ in equation (6) of DFIG modelling

$$I_{qr} = -\frac{L_s}{L_m} I_{qs} \quad (33)$$

Similarly I_{dr} is written in terms of I_{ds} and ϕ_{ds}

$$I_{dr} = -\frac{L_s}{L_m} I_{ds} + \frac{1}{L_m} \phi_{ds} \quad (34)$$

From DFIG modelling:

$$\phi_{qr} = L_r I_{qr} + L_m (I_{qs} + I_{qr})$$

$$\phi_{dr} = L_r I_{dr} + L_m (I_{ds} + I_{dr})$$

Substituting the values of I_{dr} & I_{qr} in the above equation:

$$\phi_{dr} = L_r \sigma I_{dr} + \frac{L_m}{L_s} \phi_{ds} \quad (35)$$

$$\phi_{qr} = \sigma L_r I_{qr} \quad (36)$$

Equation (3) & (4) from DFIG modelling can be re-written as

$$V_{qr} = R_r I_{qr} + (\omega_e - \omega_r) \sigma L_r I_{dr} + \sigma L_r \frac{dI_{qr}}{dt} + (\omega_e - \omega_r) \frac{L_m}{L_s} \phi_{ds} \quad (37)$$

$$V_{dr} = R_r I_{dr} - (\omega_e - \omega_r) \sigma L_r I_{qr} + \sigma L_r \frac{dI_{dr}}{dt} + \frac{L_m}{L_s} \frac{d\phi_{ds}}{dt} \quad (38)$$

Equations (37) and (38) can be expressed as control equations having compensating terms as:

$$V_{dr} = (k_{p3} + k_{i3} \int)(I_{dr}^* - I_{dr}) - (\omega_e - \omega_r) L_r I_{qr} \quad (39)$$

$$V_{qr} = (k_{p4} + k_{i4} \int)(I_{qr}^* - I_{qr}) + (\omega_e - \omega_r) L_r I_{dr} + (\omega_e - \omega_r) \frac{L_m}{L_s} \phi_{ds} \quad (40)$$

Where I_{dr}^* and I_{qr}^* are the desired components of rotor currents derived from the desired reactive power and active power respectively. Active power component is obtained from the desired speed which in turn is obtained from MPPT curve of wind turbine.

4.1.1. Stator Flux Estimation

It is calculated mathematically using the following equations.

$$\phi_{\beta s} = \int (V_{\beta s} - R_s I_{\beta s}) dt \quad (41)$$

$$\phi_{\alpha s} = \int (V_{\alpha s} - R_s I_{\alpha s}) dt \quad (42)$$

$$\phi_s = \sqrt{(\phi_{\alpha s})^2 + (\phi_{\beta s})^2} \quad (43)$$

$$\theta_s = \tan^{-1} \frac{\phi_{\beta s}}{\phi_{\alpha s}} \quad (44)$$

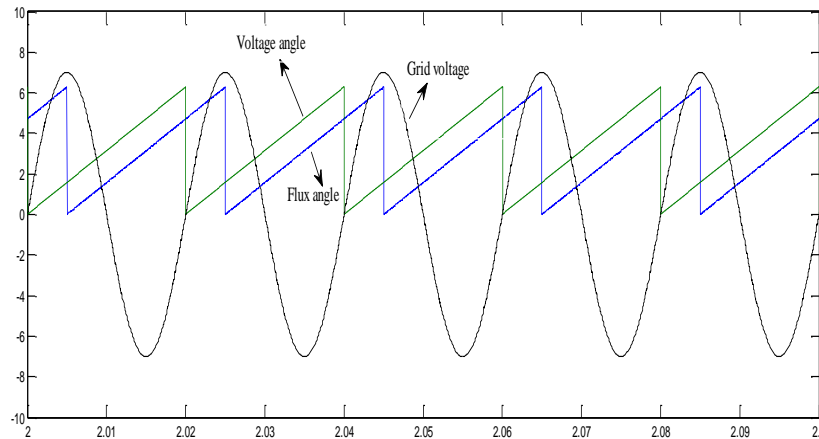

Figure 6. Orientation of Flux w.r.t. Grid Voltage

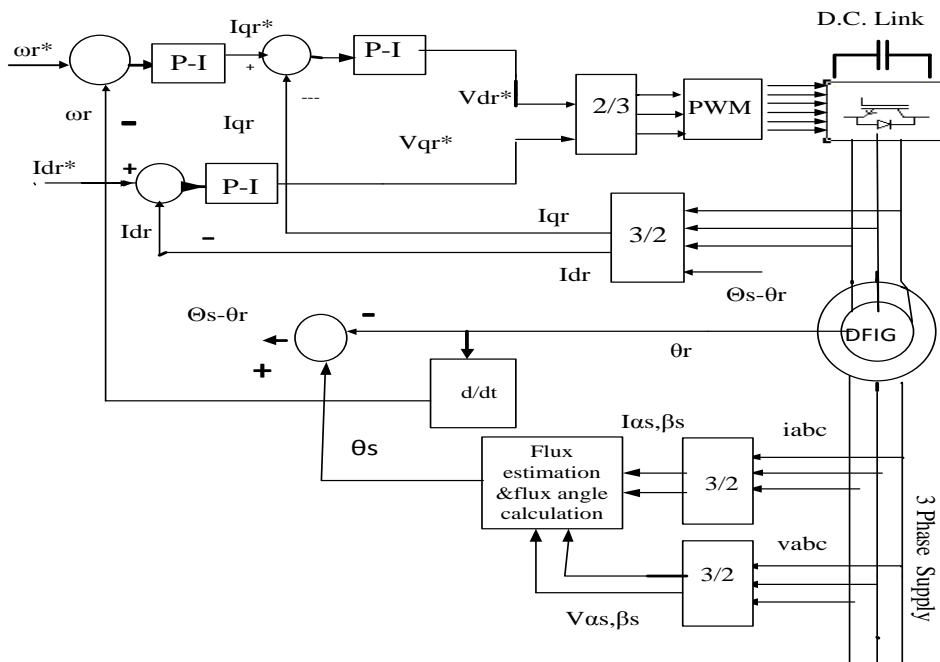

Figure 7. Vector Control for Rotor Side Converter in Stator Flux Orientation

5. Wind Turbine Rating & Specifications

Wind turbine has been designed to produce 1.5 Mw at 12m/s. The mechanical power developed by the wind turbine given by the equation:

$$P_m = 0.5C_p \pi r^2 \rho v_w^3 \quad (45)$$

$$C_p(\lambda, \beta) = 0.22[116 / \lambda_i - 0.4 * \beta - 5]e^{-12.5/\lambda_i} \quad (46)$$

Where

$$1 / \lambda_i = 1 / (\lambda + 0.08\beta) - 0.035 / \beta^3 + 1 \quad (47)$$

C_p - λ curve is shown in Figure C_{pmax} is 0.4379 and λ_{opt} is 6.45. Substituting the values of C_p , v_w and ρ in equation (45) to obtain radius[13] as

$$r_w = \sqrt{1.5 * 10^6 / [0.5 * .4379 * 1.225 * \pi * 12^3]} = 32m$$

Generator speed corresponding to rated power was considered to be 1.2p.u. i.e., 188 rad/sec. Hence gear ratio is calculated as:

$$\eta_w = \omega_r r_w / \lambda_{opt} v_w = 188 * 32 / 6.45 * 12 = 77.7 \approx 78$$

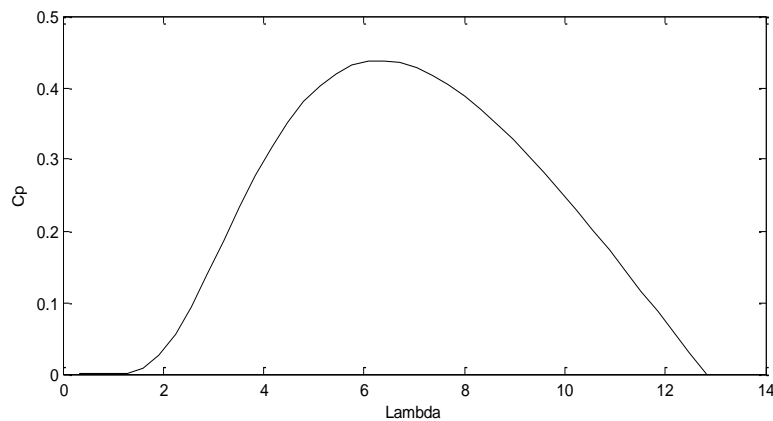

Figure 8. C_p -Lambda Curve

6. Results and Discussion

Simulation has been done on a 1.5 Mw, 690V, 50 Hz, 4 pole DFIG. Maximum power point tracking has been done by obtaining a look up table of maximum power points and the corresponding turbine speed for different values of wind speeds. The desired value of generator speed has been achieved using a PI controller in rotor converter control and deriving the reference value of I_{dr} from the error in speed in case of stator voltage oriented control and that of I_{qr} in stator flux oriented control. Figure 9 shows the performance of the system when rotor converter is controlled in stator flux oriented reference frame. At $t=3$ sec., there is a change in wind speed from 9m/s to 12m/s. Rotor speed variation is from 0.9pu to 1.1pu. Reactive power is maintained at zero for unity power factor operation. Active power varies from 0.6 Mw to 1.42 Mw. There is an increase in I_{qr} corresponding to active power increase from 0.6 Mw to 1.42 Mw while change in I_{dr} is zero. On the other hand, Figure 10 shows the waveforms of the system when rotor converter is controlled using stator voltage oriented frame of reference. In this case, voltage is oriented along d-axis. $V_{qr} = 0$. So, active power $\propto V_{dr}$ & hence I_{dr} . With the change in wind speed, there is a change in active power but this change reflects in the change of I_{dr} while there is no change in I_{qr} .

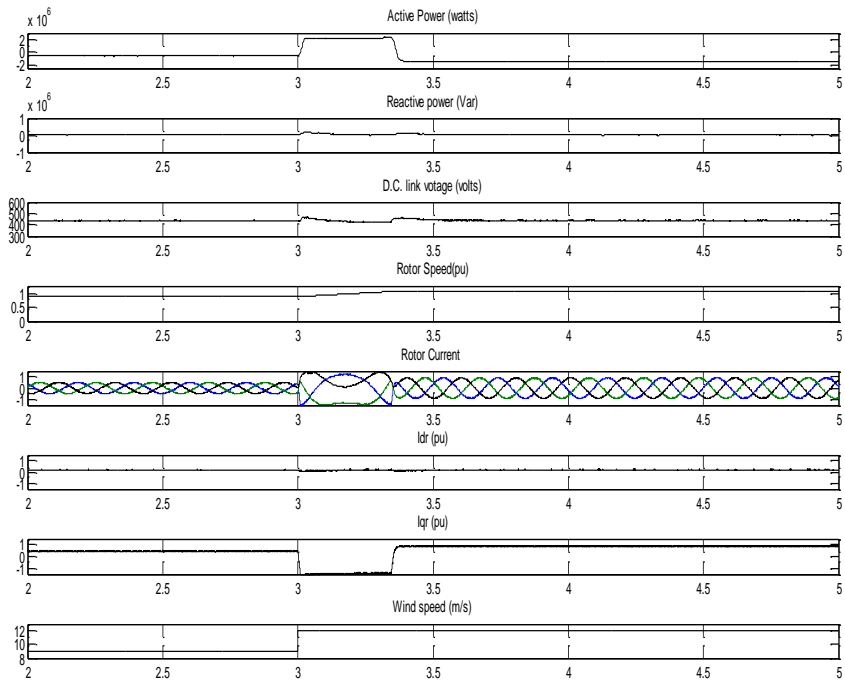

Figure 9. Performance of the System with Stator Flux Oriented Control of Rotor Side Converter

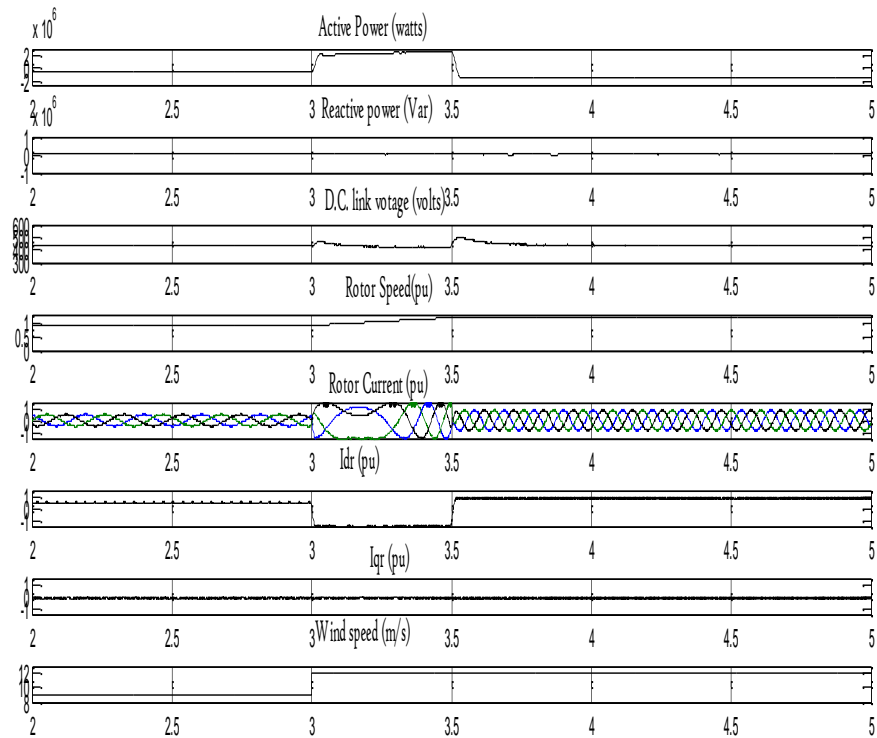

Figure 10. Performance of the System with Grid Voltage Oriented Control of Rotor Side Converter

7. Conclusion

Complete mathematical formulation of rotor side converter control using grid voltage oriented control as well as stator flux orientation control has been derived from the basic equations used in DFIG modelling. Both the control strategies have been simulated in MATLAB for a 1.5 Mw, 690 volts, 50 Hz, 4 pole DFIG connected to grid. The performance of the system using both the techniques has been shown in Figures 9 and 10. Stator flux oriented control is useful for standalone wind energy conversion systems as there is no grid and fixed stator voltage which could be used for vector orientation purposes.

Appendix A

List of abbreviations and symbols

I_{qs}, I_{ds}	Quadrature, direct axis stator currents
I_{qr}, I_{dr}	Quadrature, direct axis rotor currents
I_{ms}	Magnetising current of the stator
L	Grid side inductance
L_m	Magnetizing inductance
L_{lr}	Rotor leakage inductance
L_{ls}	Stator leakage inductance
L_s	Total stator inductance
L_r	Total rotor inductance
p	Total number of poles of DFIG
P_s	Stator active power
P_r	Rotor active power
P_m	Mechanical power of turbine
Q_r	Rotor reactive power
Q_s	Stator reactive power
R	Grid side resistance
R_r	Rotor resistance
R_s	Stator resistance

T_e Electromagnetic torque of DFIG

V_{dc} D.C. link voltage

k_p, k_i Proportional and Integral gains for grid side and rotor side converters

Appendix B

Parameters of 1.5 Mw 690 V 50 Hz 4 pole DFIG: $R_s = 0.0084 pu$, $R_r = 0.0083 pu$,
 $L_{ls} = 0.167 pu$, $L_{lr} = 0.1323 pu$, $L_m = 5.419 pu$

References

- [1] M.G. Simoes and F.A. Farret, "Alternative Energy-systems", CRC Press, (2008).
- [2] I. Boldea, "Variable Speed Generators", CRC Press, (2006).
- [3] R. Pena, J. Clare and G. Asher, "Doubly fed Induction Generator Using Back to Back PWM Converters and its Applications to Variable Speed Wind Energy Generation", IEE Electrical Power, vol. 3, (1996), pp.153
- [4] R. Pena, J. Clare and G. Asher, "A Doubly Fed Induction Generator Using Back to Back PWM Converters Supplying an Isolated Load from a Variable Speed Wind Turbine, "IEE Electrical Power, vol. 5, (1996), pp. 143.
- [5] R. Pena, R. Cardenas, G. Asher and J. Clare, "Vector Controlled Induction Machine for Stand-alone Wind Energy Applications", Proceedings of IEEE Industry Application Conf., (2000) October; Rome, Italy.
- [6] S. Muller, M. Deicke and R.W. De Doncker, "Doubly Fed Induction Generator Systems for Wind Turbines, IEEE Industry Applications Magazine, vol. 8, no. 3, (2002).
- [7] R. Cardenas, R. Pena, G. Asher and J. Cilia, "Sensorless Control of Induction Machines for Wind Energy Applications", Proceedings of IEEE Power Electronics Specialists conf., (2002) June 23-27; Cairns, Queensland, Australia.
- [8] J.B. Ekanayake, L. Holdsworth and G.W. Xue, "Dynamic Modeling of Doubly Fed Induction Generator Wind Turbines, IEEE Trans. on Power Systems, vol. 18, no. 2, (2003).
- [9] A. Tapia, G. Tapia, J.X. Ostolaza and J. R. Sanes, "Modeling and Control of a Wind Turbine Driven Doubly Fed Induction Generator", IEEE Trans. on Energy Conv., vol. 18, no.2, (2003).
- [10] S.Y. Yang, X. Zhang , C.W. Zhang and L. Chang, "Development of a Variable-Speed Wind Energy Conversion System Based on Doubly-Fed Induction Generator", Proceedings of IEEE 22nd annual Applied Power Electronics conf, (2007) February-March; Anaheim, CA, USA.
- [11] K. Hee-Sang, Y. Gi-Gab and H. Won-Pyo, "Active Use of DFIG-Based Variable-Speed Wind-Turbine for Voltage Regulation at a Remote Location", IEEE Trans on Power Systems, vol. 2, no. 4, (2007).
- [12] A. Jain and V.T. Ranganathan, "Wound Rotor Induction Generator With Sensorless Control and Integrated Active Filter for Feeding Nonlinear Loads in a Stand-Alone Grid", IEEE Trans. on Industrial Electronics, vol. 55,no.1, (2008).
- [13] P.K. Goel, B. Singh, S.S. Murthy and N. Kishore, "Isolated Wind-Hydro Hybrid System Using Cage Generators and Battery Storage", IEEE Trans. on Industrial Electronics, vol. 58, no. 4, (2011).
- [14] H. Karimi-Davijani , A. Sheikholeslami, H. Livani and N. Norouzi, "Fault ride-through Capability Improvement of Wind Farms Using Doubly Fed Induction Generator", Proceedings of 43rd International Universities Power Engineering conf., (2008) September 1-4; Padova.